

Model			GWH24AODXF-K6DNA1B
Product Code			CB603001001/CB603001002/CB603001003
Power Supply	Rated Voltage	V~	220-240
	Rated Frequency	Hz	50
	Phases		1
Power Supply Mode			Outdoor
Cooling Capacity		W	6500
Heating Capacity		W	7034
Cooling Power Input		W	1700
Heating Power Input		W	1980
Cooling Current Input		A	7.5
Heating Current Input		A	9.5
Rated Input		W	4000
Rated Cooling Current		A	13
Rated Heating Current		A	17.5
Air Flow Volume		m ³ /h	1000/850/760/580/520/450/400/280
Dehumidifying Volume		L/h	2.4
EER		W/W	3.82
COP		W/W	3.55
SEER			8.5
SCOP(Average/WarmerColder)			4.4/6.0/3.5
Application Area		m ²	27-42
Indoor Unit	Model		GWH24AODXF-K6DNA1B/I
	Product Code		CB603N01000/CB603N01002/CB603N01003
	Fan Type		Cross-flow
	Fan Diameter Length(DXL)	mm	Φ106×739
	Cooling Speed	r/min	1400/1200/1120/1050/980/860/750/550
	Heating Speed	r/min	1400/1200/1120/1050/950/850/750
	Fan Motor Power Output	W	45
	Fan Motor RLA	A	0.25
	Fan Motor Capacitor	μF	/
	Evaporator Form		Aluminum Fin-copper Tube
	Evaporator Pipe Diameter	mm	Φ7
	Evaporator Row-fin Gap	mm	2-1.4
	Evaporator Coil Length (LXDXW)	mm	745×22.8×342.9
	Swing Motor Model		MP24AK/MP24HF/MP24BA
	Swing Motor Power Output	W	1.5/1.5/1.5
	Fuse Current	A	3.15
	Sound Pressure Level	dB (A)	Cooling:48/43/41/39/37/33/29/23 Heating:50/44/42/40/36/33/30
	Sound Power Level	dB (A)	Cooling:64/57/55/53/51/47/43/37 Heating:64/58/56/54/50/47/44
	Dimension (WXHDXD)	mm	993×311×222
	Dimension of Carton Box (LXWXH)	mm	1050×377×288
Dimension of Package (LXWXH)	mm	1055×385×298	
Net Weight	kg	13.5	
Gross Weight	kg	16	

Outdoor Unit	Outdoor Unit Model		GWH24AODXF-K6DNA1B/O(LCLH)
	Outdoor Unit Product Code		CB603W01001
	Compressor Manufacturer		ZHUHAI LANDA COMPRESSOR CO.,LTD
	Compressor Model		QXFS-A150zX170S
	Compressor Oil		FW68DA or equivalent
	Compressor Type		Rotary
	Compressor LRA.	A	35
	Compressor RLA	A	11.35
	Compressor Power Input	W	1330
	Compressor Overload Protector		/
	Throttling Method		Electron expansion valve
	Set Temperature Range	°C	16~30
	Cooling Operation Ambient Temperature Range	°C	-15~50
	Heating Operation Ambient Temperature Range	°C	-25~30
	Condenser Form		Aluminum Fin-copper Tube
	Condenser Pipe Diameter	mm	Φ7.94
	Condenser Rows-fin Gap	mm	2-1.4
	Condenser Coil Length (LXDXW)	mm	934×38.1×616
	Fan Motor Speed	rpm	800
	Fan Motor Power Output	W	60
	Fan Motor RLA	A	1.5
	Fan Motor Capacitor	μF	/
	Outdoor Unit Air Flow Volume	m ³ /h	3600
	Fan Type		Axial-flow
	Fan Diameter	mm	Φ520
	Defrosting Method		Automatic Defrosting
	Climate Type		T1
	Isolation		I
	Moisture Protection		IPX4
	Permissible Excessive Operating Pressure for the Discharge Side	MPa	4.3
	Permissible Excessive Operating Pressure for the Suction Side	MPa	2.5
	Sound Pressure Level	dB (A)	58
	Sound Power Level	dB (A)	70
Dimension(WXHXD)	mm	958×660×402	
Dimension of Carton Box (LXWXH)	mm	1029×453×715	
Dimension of Package(LXWXH)	mm	1032×456×737	
Net Weight	kg	42.5	
Gross Weight	kg	47	
Refrigerant		R32	
Refrigerant Charge	kg	1.3	
Connection Pipe	Connection Pipe Length	m	5
	Connection Pipe Gas Additional Charge	g/m	40
	Outer Diameter Liquid Pipe	inch	1/4
	Outer Diameter Gas Pipe	inch	5/8
	Max Distance Height	m	10
	Max Distance Length	m	25
	Note: The connection pipe applies metric diameter.		

The above data is subject to change without notice. Please refer to the nameplate of the unit.

2.2 Capacity Variation Ratio According to Temperature

Heating operation ambient temperature range is -25°C~30°C

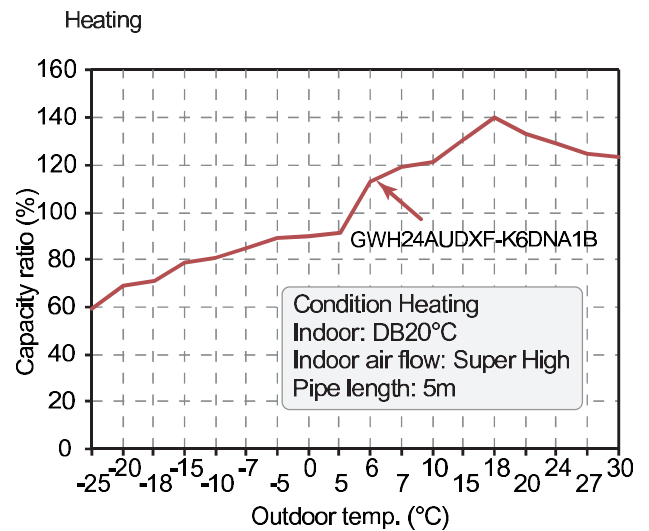
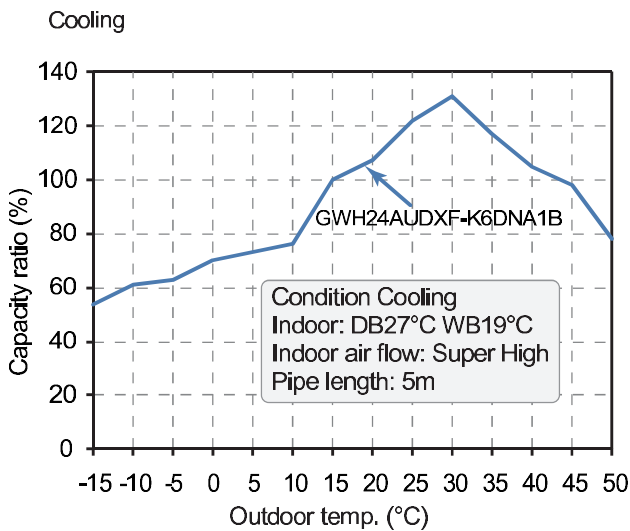
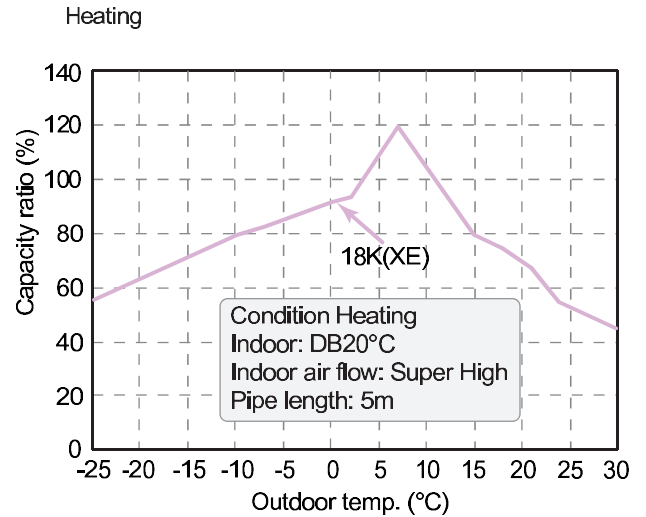
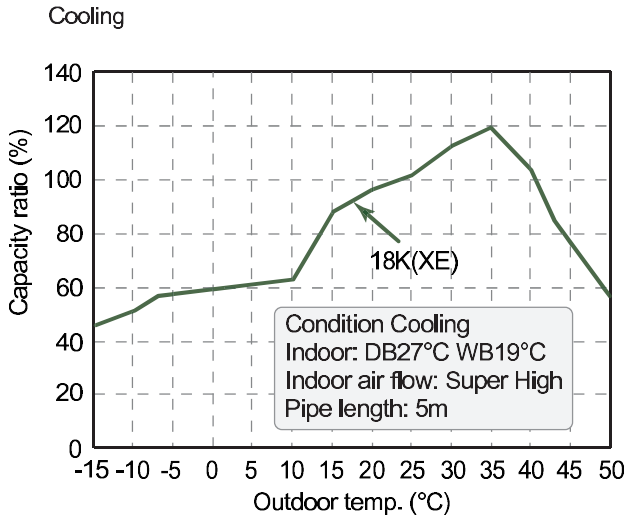
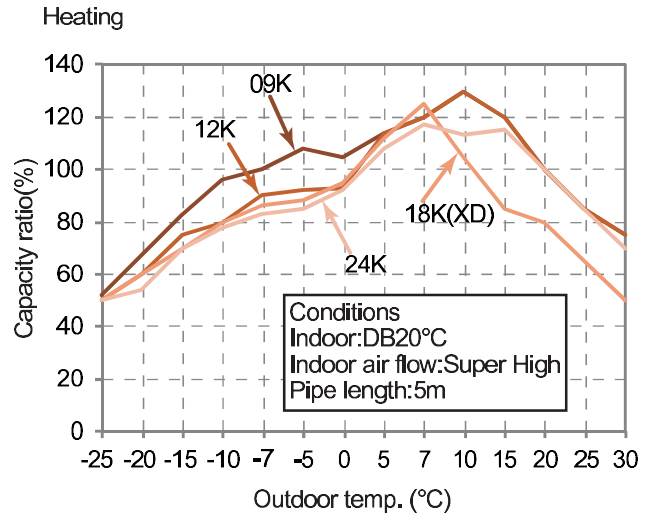
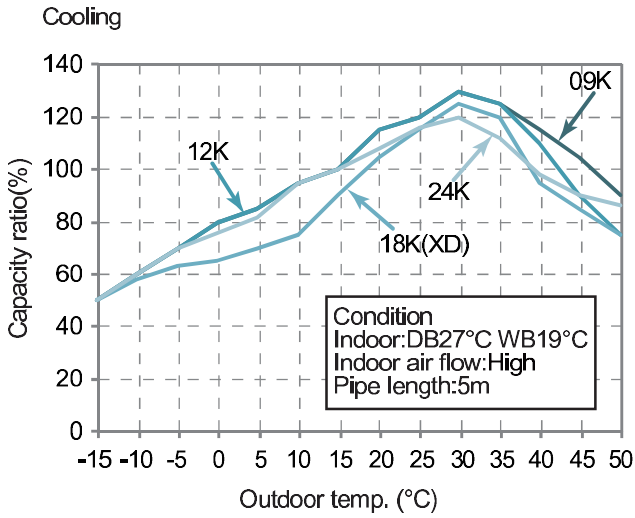

Heating operation ambient temperature range is -15°C~30°C

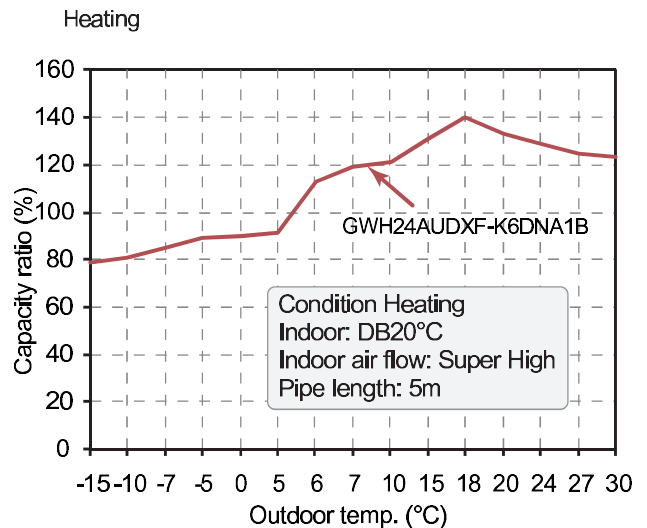
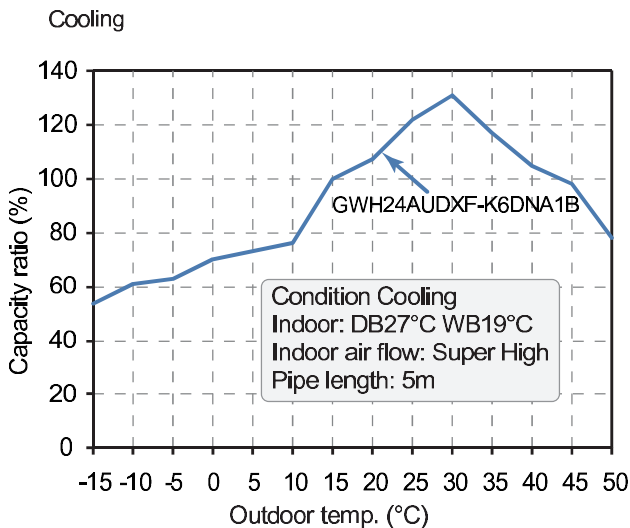
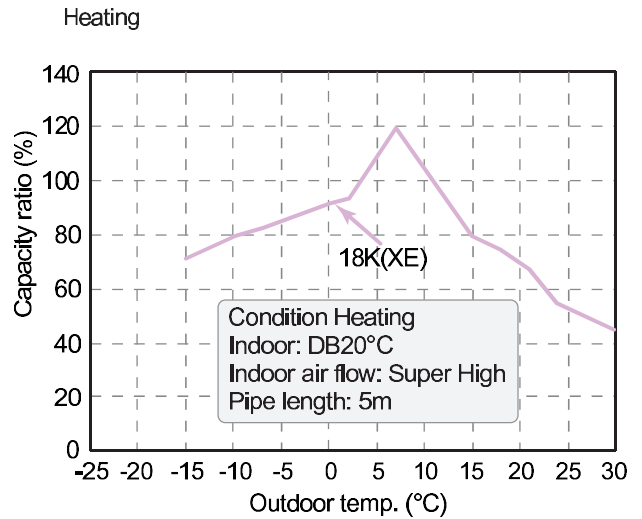
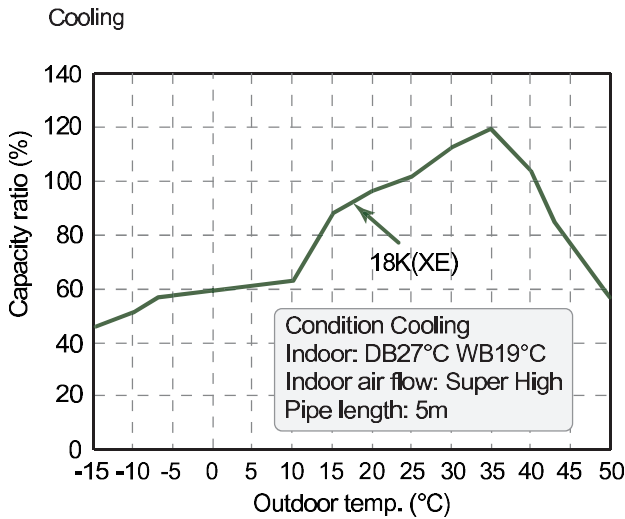
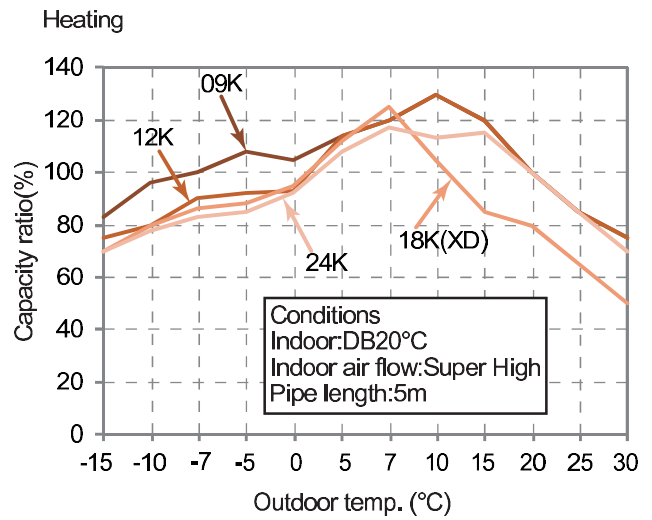
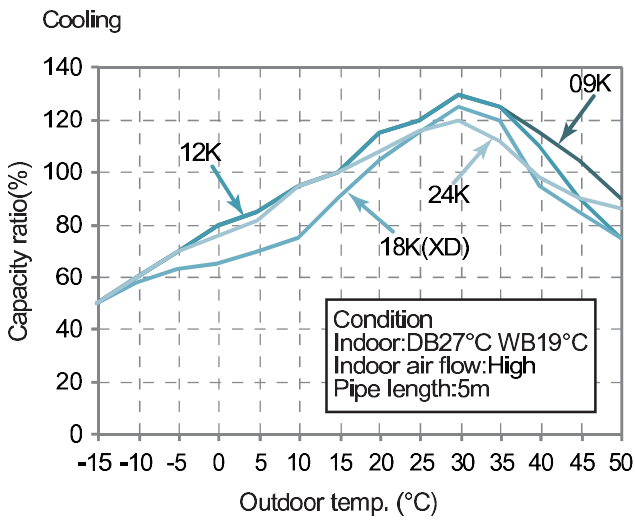

3. Outline Dimension Diagram

3.1 Indoor Unit

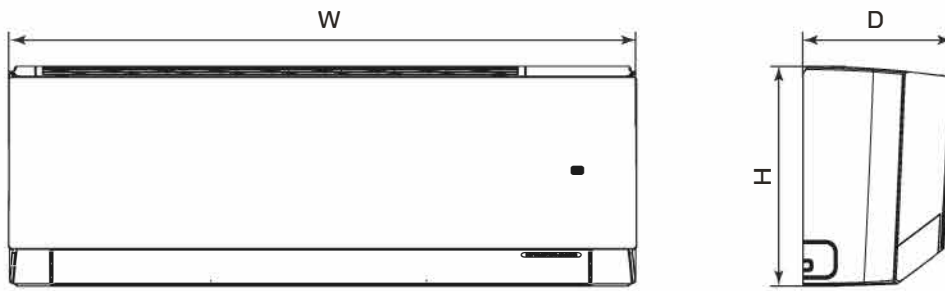

AOC

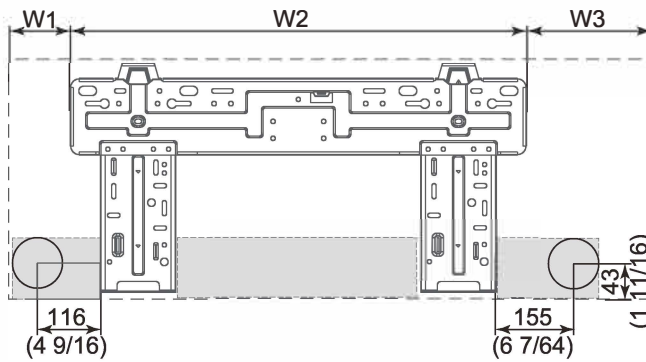

AOD

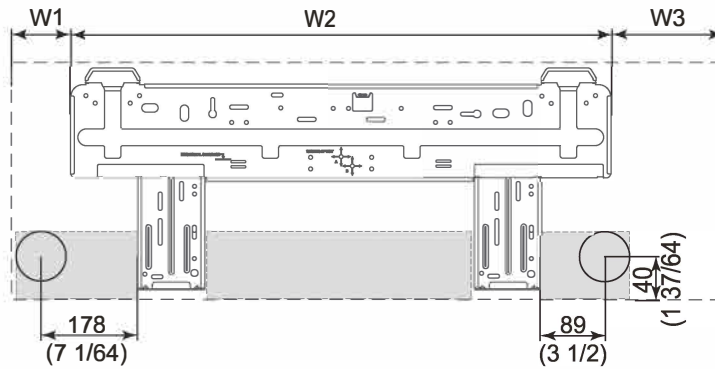

Unit: mm

Model	W	H	D	W1	W2	W3
AOC	837	293	200	119	542	176
AOD	993	311	222	128	707.5	157.5

GWH18AUDXE-K6DNA1A/O GWH18AUDXE-K6DNA1B/O GWH18AUDXE-K6DNA2C/O

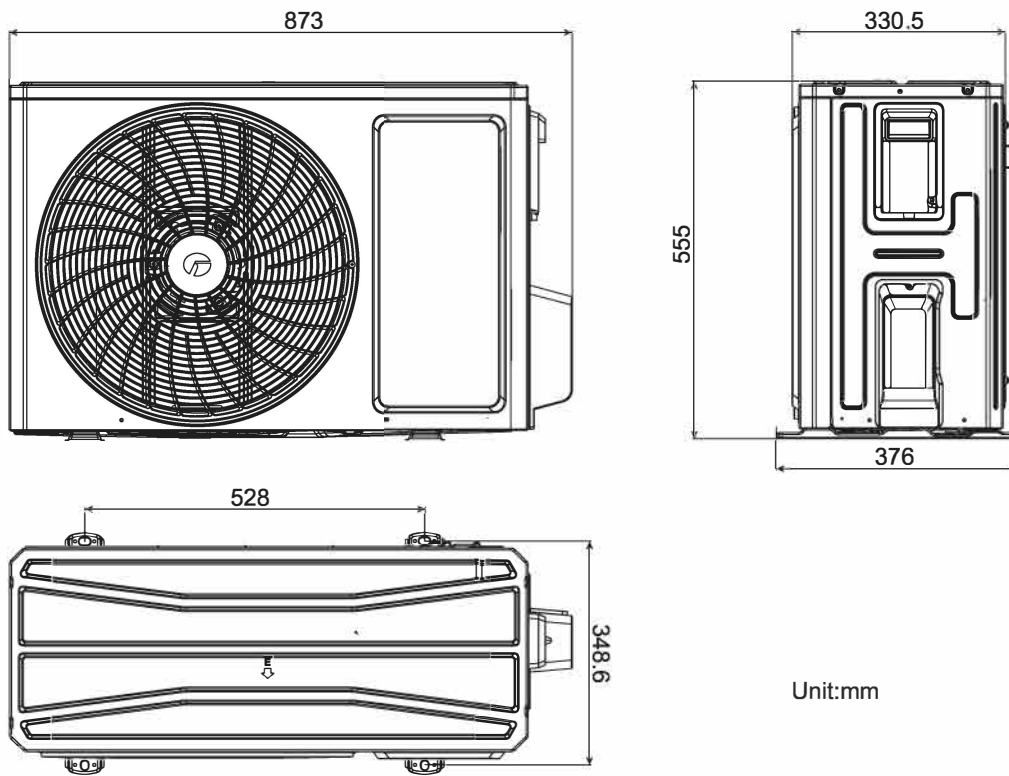

GWH24AODXF-K6DNA1A/O GWH24AODXF-K6DNA1B/O

